



# CITY OF BULLHEAD CITY

## AWNING / CARPORT

### (RESIDENTIAL)

This list has been compiled in order to outline the most common type of Residential Awning / Carport submittal. All requirements for a specific project type may not be listed. It is the applicant's responsibility to verify specific conditions of approval. If you have questions contact City staff for clarification prior to submittal at 928-763-0124. Failure to provide a complete submittal, as outlined below, may cause delays in the processing of your permit.

#### **GENERAL REQUIREMENTS FOR RESIDENTIAL PLAN SUBMITTAL:**

- One (1) completed permit application worksheet.
- Two (2) 8 1/2" x 11" site plans.
- Two (2) complete sets of PLANS.
- Two (2) complete sets of roof truss layouts and calculations (as applicable to project).
- Two (2) complete sets of structural calculations for areas of unconventional construction, or as required by the Arizona Board of Technical Registration (as applicable to project).
- If the Awning / Carport is to be "attached" and the primary structure is a manufactured home the proposed Carport / Awning must be structurally independent.
- If the property has a septic tank provide a copy of the proposed site plan approved by the Mohave County Development Services Department.
- Plan review fees are collected at the time of submittal.

Items that require design by a registrant, per the building code or the Arizona Board of Technical Registration, are to be sealed and signed by an Arizona licensed registrant. City ordinance requires one set to contain the registrant's original signature the second set can be a copy.

#### **PLANS**

To be on minimum 8 1/2" x 11" sheets, fully dimensioned and to scale, to include:

- Site Plan
- Floor Plan
- Exterior Elevations
- Foundation Plan
- Framing Plan
- Cross Sections and Details
- Electrical, Mechanical and Plumbing Plans (as applicable – may be combined or on separate sheets)
- Soils Report: In areas likely to have expansive, compressible, shifting or other unknown soil characteristics, you may be required to provide a soil test to determine the soil's characteristics at a particular location. If required this test shall be made by an approved agency using an approved method.

#### **OTHER REQUIRED INFORMATION:**

Contractor / Owner Builder:

- General Contractor:
  - Provide contractor's AZ Registrar of Contractor's license number.
  - For projects with a valuation of \$50,000.00 or more, contractors are to provide a copy of their Arizona Department of Revenue, Bond Exemption Certificate or a One-time Bond Exemption.
  - Provide contractor's TPT number.
  - Provide contractor's City of Bullhead City business license number.
- Owner Builder (restrictions apply):
  - Provide a signed 'Declaration of Intent' form.

## **GENERAL INFORMATION**

- See permit “Building and Zoning Permits Guide” for review timelines.
- Separate permits may be required for other related work such as grading, retaining walls, etc.
- A separate Flood Plain Development permit is required if lot is in a FEMA designated flood zone.
- A separate permit is required for construction within the City’s right-of-way or easements such as driveway approaches, sidewalks, etc.
- For wood structures a soil treatment report from an Arizona licensed pest control agency for the prevention of termite infestation is required prior to final inspection.

## **PERMIT INFORMATION:**

- A twenty-four (24) hour inspection request line is available, call (928) 763-0172.
- The permit inspection card must be posted on the construction site at all times.
- The approved plans must be on the job site for all requested inspections
- Prior to digging call *Arizona 811*; in AZ dial 811, out of state 1-800-STAKE-IT (1-800-782-5348)
- Temporary restroom facilities and a minimum three cubic yard trash receptacle are required.

## **ADOPTED BUILDING CODES (with local amendments):**

Title	Code Year	BHC MC Chapter	Title	Code Year	BHC MC Chapter
International Building Code, ICC	2018	15.12	International Fire Code, ICC	2018	15.24
International Residential Code, ICC	2018	15.14	International Energy Conservation Code, ICC	2018	15.22
National Electric Code, NFPA	2017	15.20	International Existing Building Code, ICC	2018	15.26
International Mechanical Code, ICC	2018	15.28	International Swimming Pool and Spa Code, ICC	2018	15.30
International Plumbing Code, ICC	2018	15.32			
International Fuel Gas Code, ICC	2018	15.34	ADAAG Manual, ADA US Access Board	2010	NA

ICC International Code Council, NFPA National Fire Protection Association

The Arizona Department of Fire, Building and Life Safety adopted the 2024 International Fire Code. For additional information contact the Bullhead City Fire Department at (928) 758-3971.

For specific Planning & Zoning codes, Engineering codes, Building codes and local code amendments, along with plan submittal requirements applicable to various project types, review our informational handouts under **Departments** and the City’s **Municipal Code** at [www.bullheadcityaz.gov](http://www.bullheadcityaz.gov).

**AWNING / CARPORT**  
(Attached to Site Built Structure)

**FOUNDATION LAYOUT**

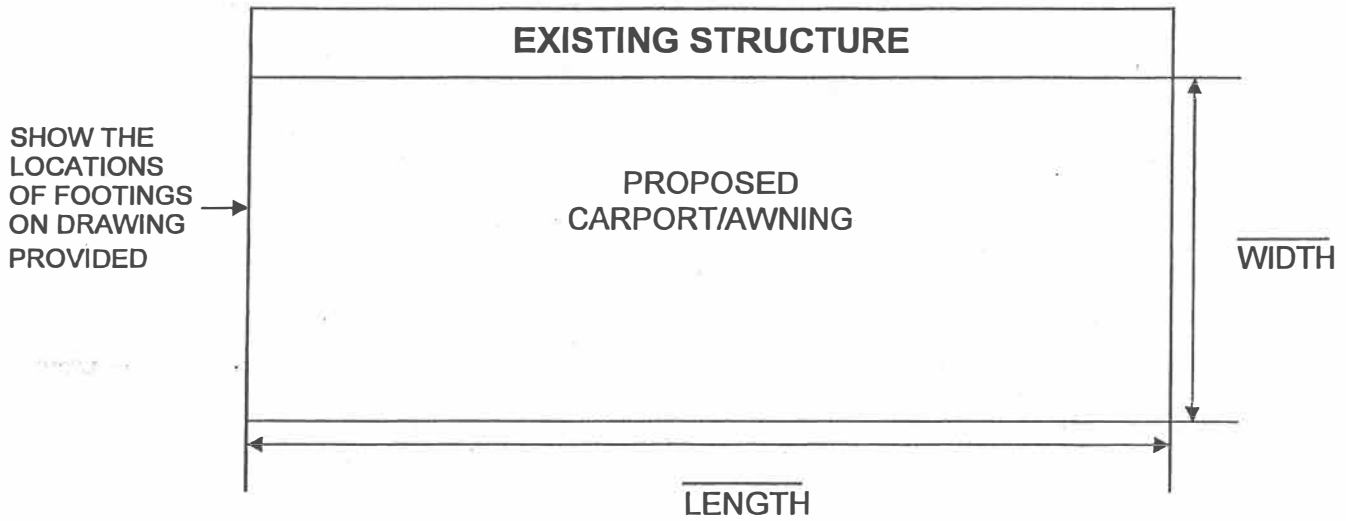

Attach \_\_\_ x \_\_\_ ledger with 1/2" x 4" lag Bolts staggered at 16" O.C. max no less than 1 1/2" material on top and bottom of the bolts & at least 2" at the end joints. Do not attach ledger or rafters to eaves, fascia or rafter tails of existing structure. The ledger is to be at least one nominal size larger than the rafter size being used.

Roofing Material/Roof Slope:  
 \_\_\_ Hot Mop / Minimum 1/4" to 12" Slope  
 \_\_\_ 90# Rolled Roofing / Minimum 1" to 12" Slope  
 \_\_\_ Asphalt Shingles / Minimum 2" to 12" Slope  
 Other: Type: \_\_\_\_\_ / Slope: \_\_\_\_\_  
 Roofing installation to meet the requirements of Chapter 9 of the 2018 IRC and the manufacturer's installation instructions.

Roof Sheathing \_\_\_\_\_  
 Minimum 1/2" plywood or equal.

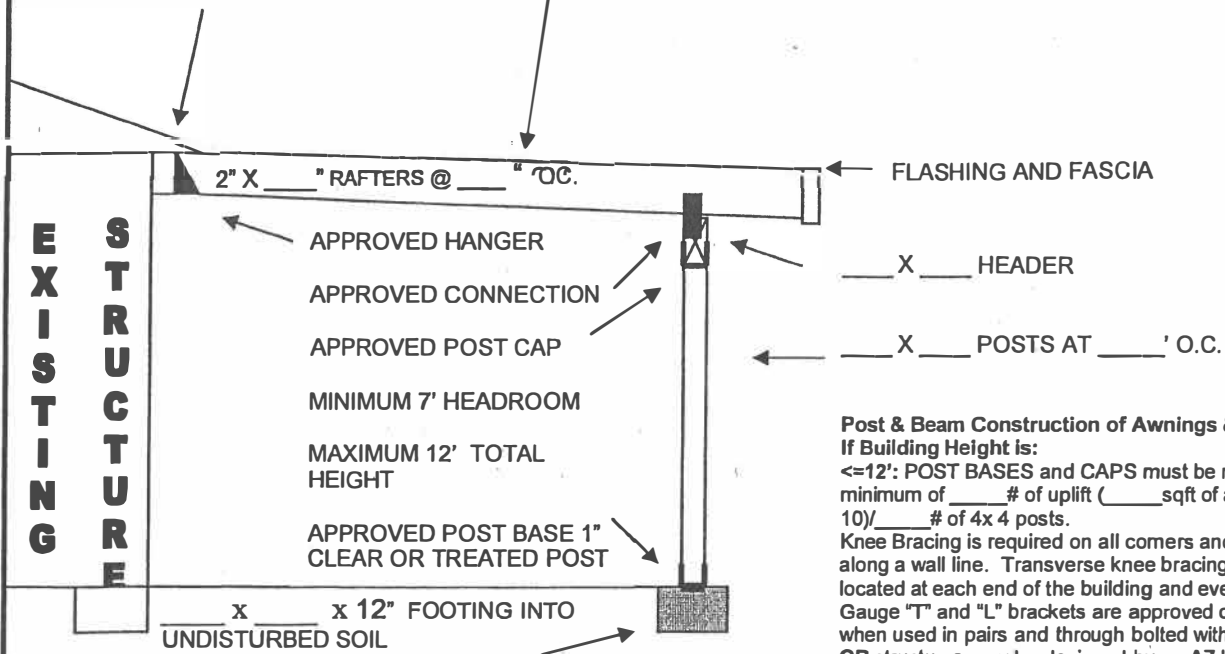

**Post & Beam Construction of Awnings & Carports:**

**If Building Height is:**  
 <=12': POST BASES and CAPS must be rated for a minimum of \_\_\_ # of uplift (\_\_\_ sqft of awning x 10) / \_\_\_ # of 4x4 posts.  
 Knee Bracing is required on all corners and every 25' along a wall line. Transverse knee bracing shall be located at each end of the building and every 25'. 12 Gauge "T" and "L" brackets are approved connectors when used in pairs and through bolted with 1/2" bolts.  
 OR structures may be designed by an AZ licensed registrant  
 >12': Building must be designed by an AZ licensed registrant

# AWNING / CARPORT (Attached to Manufactured Home)

- If the awning / carport is to be "attached" and the primary structure is a manufactured home, the proposed awning / carport must be structurally independent.

## FOUNDATION LAYOUT

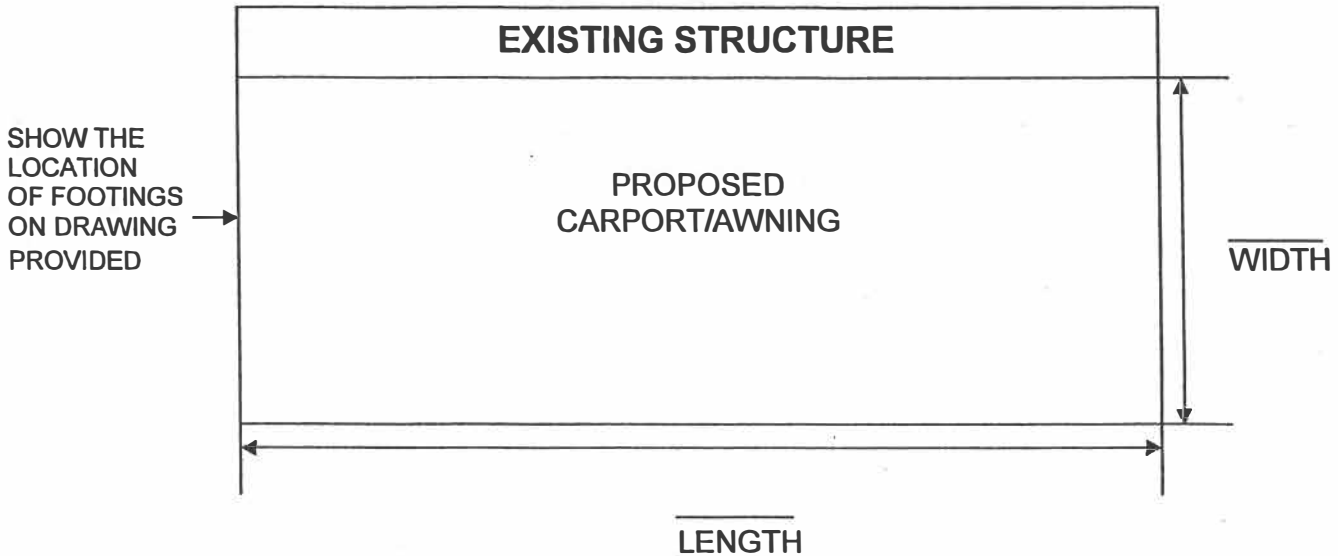

Do not attach ledger or rafters to eaves, fascia or rafter tails of existing structure.

Roofing Material/Roof Slope:  
 \_\_\_ Hot Mop/ Minimum 1/4" to 12" Slope  
 \_\_\_ 90# Rolled Roofing | Minimum 1" to 12" Slope  
 \_\_\_ Asphalt Shingles / Minimum 2" to 12" Slope  
 \_\_\_ Other: Type: \_\_\_\_\_ / Slope: \_\_\_\_\_  
 \_\_\_ Roofing installation to meet the requirements of Chapter 9 of the 2018 IRC and the manufacturer's installation instructions.

Roof Sheathing \_\_\_\_\_  
 Minimum 1/2" plywood or equal.

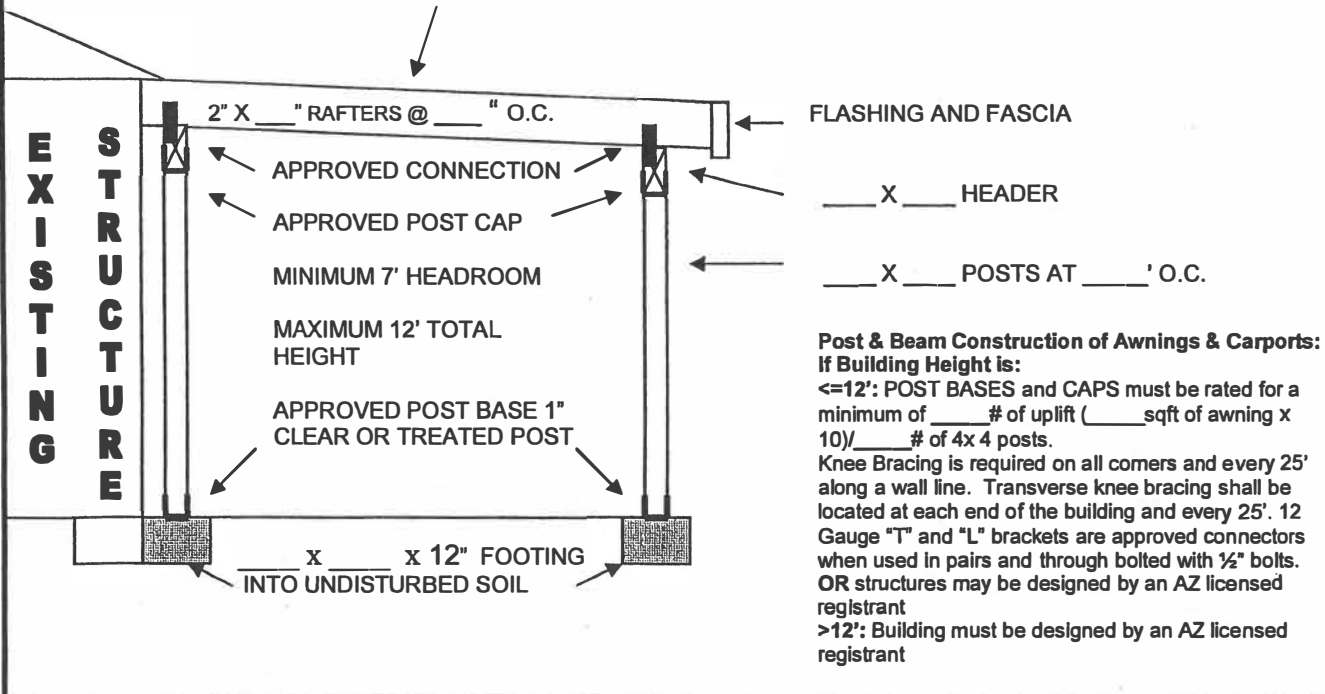

**Post & Beam Construction of Awnings & Carports:**  
**If Building Height is:**  
 <=12': POST BASES and CAPS must be rated for a minimum of \_\_\_# of uplift (\_\_\_sqft of awning x 10)/\_\_\_# of 4x 4 posts.  
 Knee Bracing is required on all corners and every 25' along a wall line. Transverse knee bracing shall be located at each end of the building and every 25'. 12 Gauge "T" and "L" brackets are approved connectors when used in pairs and through bolted with 1/2" bolts.  
 OR structures may be designed by an AZ licensed registrant  
 >12': Building must be designed by an AZ licensed registrant

In lieu of the bracing prescribed in the International Residential Code, carports and patio covers may have knee bracing located as required for prescriptive wall bracing. If used, the required knee bracing shall extend diagonally at a 45° angle from the post to the beginning not less than 24" from the intersection of the post and beam. The required bracing shall be positively connected with lag bolts, gussets or other approved means.

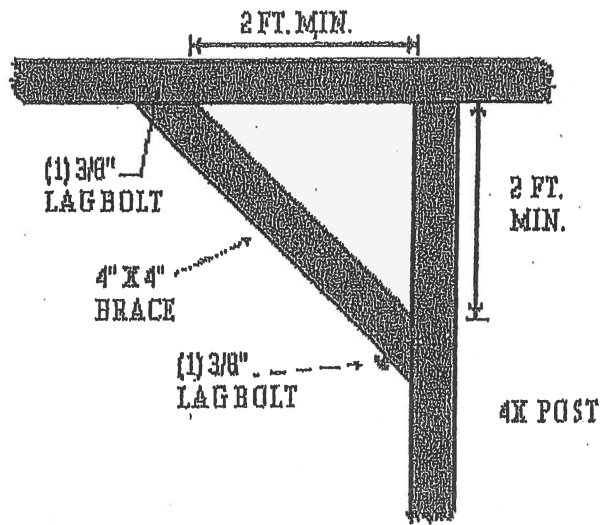

**Knee Brace Detail**

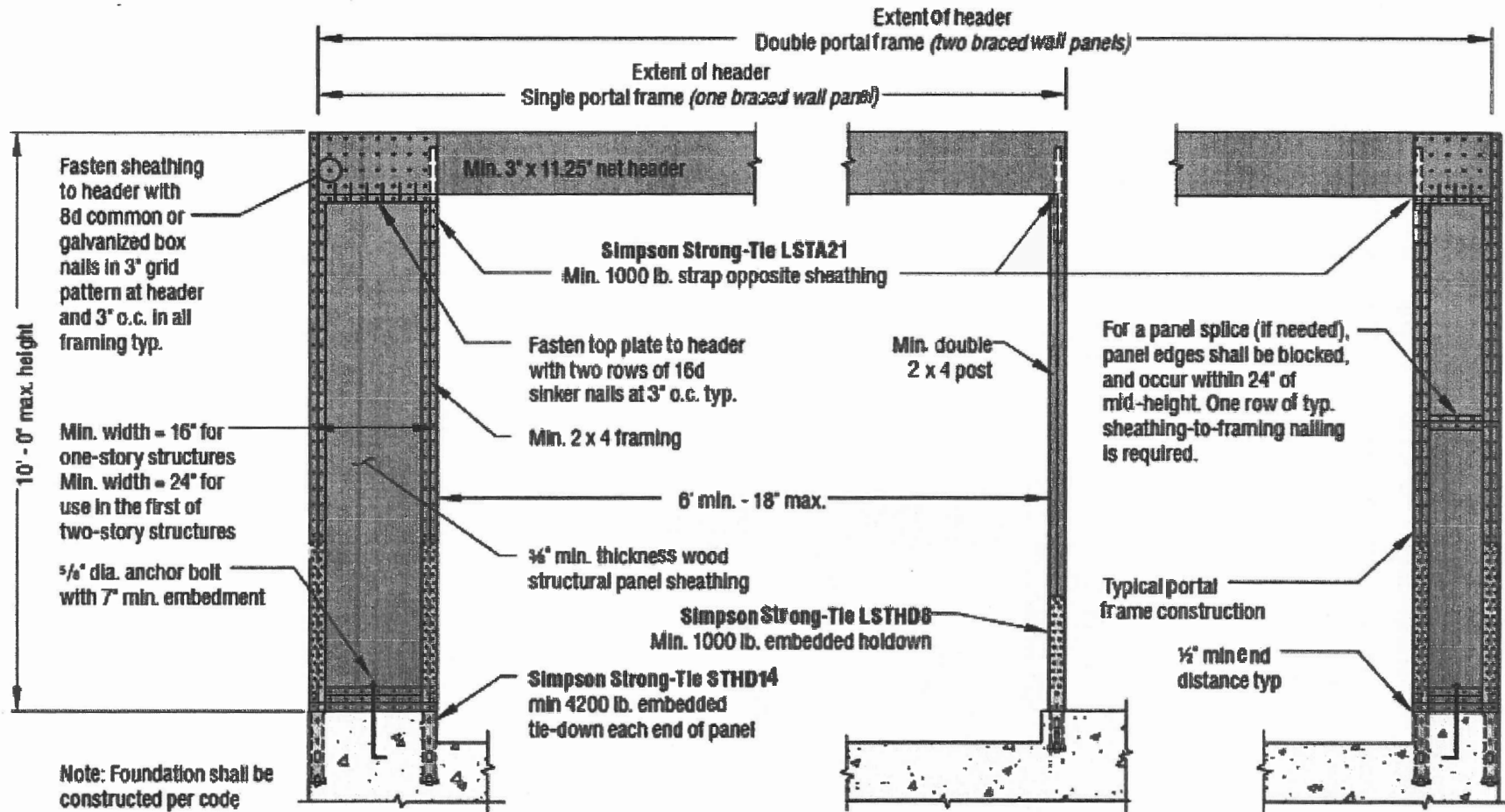

**Method PFH: Portal Frame with Holdowns**

**CITY OF BULLHEAD CITY**  
DEVELOPMENT SERVICES  
2355 TRANE ROAD  
BULLHEAD CITY, AZ 86442  
Office: 928-763-0124  
Fax: 928-763-0131

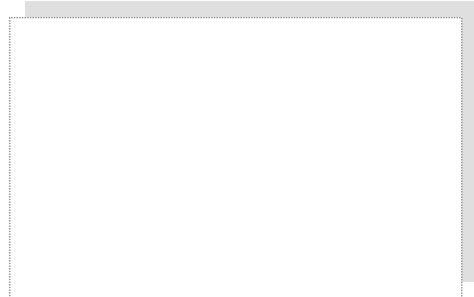

# PERMIT APPLICATION

LOG NUMBER: \_\_\_\_\_

PERMIT NUMBER: \_\_\_\_\_

**PROJECT ADDRESS:** \_\_\_\_\_

Project Description: \_\_\_\_\_ Project Valuation: \$ \_\_\_\_\_

## LEGAL DESCRIPTON:

A.P.N: \_\_\_\_\_ - \_\_\_\_\_ - \_\_\_\_\_ Subdivision: \_\_\_\_\_  
ASSESSOR PARCEL NUMBER

Tract: \_\_\_\_\_ Block: \_\_\_\_\_ Lot: \_\_\_\_\_ Parcel: \_\_\_\_\_ M&B: SEC. \_\_\_\_\_, T \_\_\_\_\_ N, R \_\_\_\_\_ W

**APPLICANT:** \_\_\_\_\_ Contact Person: \_\_\_\_\_

Mailing Address: \_\_\_\_\_

City: \_\_\_\_\_ State: \_\_\_\_\_ Zip Code: \_\_\_\_\_

### Phone Numbers

(Home/Office): \_\_\_\_\_ Cell : \_\_\_\_\_ Fax : \_\_\_\_\_

Email Address: \_\_\_\_\_

## PROPERTY

**OWNER:** \_\_\_\_\_

Mailing Address: \_\_\_\_\_

City: \_\_\_\_\_

State: \_\_\_\_\_ Zip Code: \_\_\_\_\_

### Phone Numbers

(Home/Office): \_\_\_\_\_

Cell : \_\_\_\_\_ Fax : \_\_\_\_\_

Email Address: \_\_\_\_\_

## OFFICE USE ONLY

### PROPERTY OWNER INFORMATION PER MOHAVE COUNTY

Owner: \_\_\_\_\_

Mailing Address: \_\_\_\_\_

City: \_\_\_\_\_

State: \_\_\_\_\_ Zip Code: \_\_\_\_\_

New Owner / Sale Date: \_\_\_\_\_

**TENANT:** \_\_\_\_\_ Contact Person: \_\_\_\_\_

Mailing Address: \_\_\_\_\_

City: \_\_\_\_\_ State: \_\_\_\_\_ Zip Code: \_\_\_\_\_

### Phone Numbers

(Home/Office): \_\_\_\_\_ Cell : \_\_\_\_\_ Fax : \_\_\_\_\_

Email Address: \_\_\_\_\_

OWNER BUILDER: (requires completion of the "Declaration of Intent" form)

-OR-

CONTRACTOR: \_\_\_\_\_ Contact Person: \_\_\_\_\_

Mailing Address: \_\_\_\_\_

City: \_\_\_\_\_ State: \_\_\_\_\_ Zip Code: \_\_\_\_\_

**Phone Numbers**

(Home/Office): \_\_\_\_\_ Cell : \_\_\_\_\_ Fax : \_\_\_\_\_

Email Address: \_\_\_\_\_

Arizona State Contractors License Number: \_\_\_\_\_

Arizona Transaction Privilege Number: \_\_\_\_\_

City of Bullhead City Business License Number: \_\_\_\_\_

**Per ARS 9-495. Employees providing assistance; identification; communication:**

A. In any written communication between a city or town and a person, the city or town shall provide the name, telephone number and email address of the employee who is authorized and able to provide information about the communication if the communication does any of the following:

1. Demands payment of a tax, fee, penalty, fine or assessment.
2. Denies an application for a permit or license that is issued by the city or town.
3. Requests corrections, revisions or additional information or materials needed for approval of any application for a permit, license or other authorization that is issued by the city or town.

B. An employee who is authorized and able to provide information about any communication that is described in subsection A of this section shall reply within five business days after the city or town receives that communication.

**Per ARS 9-834. Prohibited acts by municipalities and employees; enforcement; notice:**

A. A municipality shall not base a licensing decision in whole or in part on a licensing requirement or condition that is not specifically authorized by statute, rule, ordinance or code. A general grant of authority does not constitute a basis for imposing a licensing requirement or condition unless the authority specifically authorizes the requirement or condition.

B. Unless specifically authorized, a municipality shall avoid duplication of other laws that do not enhance regulatory clarity and shall avoid dual permitting to the maximum extent practicable.

C. This section does not prohibit municipal flexibility to issue licenses or adopt ordinances or codes.

D. A municipality shall not request or initiate discussions with a person about waiving that person's rights.

E. This section may be enforced in a private civil action and relief may be awarded against a municipality. The court may award reasonable attorney fees, damages and all fees associated with the license application to a party that prevails in an action against a municipality for a violation of this section.

F. A municipal employee may not intentionally or knowingly violate this section. A violation of this section is cause for disciplinary action or dismissal pursuant to the municipality's adopted personnel policy.

G. This section does not abrogate the immunity provided by section 12-820.01 or 12-820.02.

H. A municipality shall prominently print the provisions of subsections A, B, C, D, E, F and G of this section on all license applications.

I. The licensing application may be in either print or electronic format.

**Warning - Plans Control:**

Once submitted to the City for review, permits and their associated construction documents are considered to belong to the property owner, as recorded with Mohave County at the time of application and permit issuance, regardless of who is listed on this application as the owner, tenant, applicant, technical registrant or contactor and regardless of who paid the associated fees to the City. The City will not determine between competing interests who has legal right to the permit and associated construction documents.

**Licensing Timelines:**

Overall timeline for application review is 60 working days consisting of: Up 15 working days for administrative review for application completeness. Up to 45 working days for substantive review of the application. (see "Building and Zoning Permits" guide for complete details) An applicant may receive clarification of the City's interpretation or application of a statute, ordinance code or policy statement impacting the application.

**Acknowledgement:**

I hereby acknowledge that the information I have provided is correct and I agree to comply with all State, County and City laws and ordinances regulating construction, and that I will advise all interested parties under this application of the licensing and plans control provisions above. I also acknowledge I am aware of CC&R's in general; that the City is not responsible for reviewing compliance with any CC&R's that apply to the project; and that in my opinion no CC&R exists or applies or has been or will be complied with. I understand and agree the City of Bullhead City has no obligation to explain every requirement and ordinance to me prior to approval of my project. I also acknowledge by signing this application I authorize any City of Bullhead City personnel access to the property at all reasonable times to ascertain relevant information, including the current condition of the property, and perform any and all inspections. The issuance of a permit based on plans, specifications and other data shall not prevent the building official from thereafter requiring the correction of errors in said plans, specifications and other data, or preventing building operations when in violation of this code or of any State, County or City laws, rules or regulations.

\_\_\_\_\_  
**Owner/Agent Signature**

\_\_\_\_\_  
**Date**

\_\_\_\_\_  
**Applicant's Signature**

\_\_\_\_\_  
**Date**

(By signing as 'Agent' I am signing on behalf of the owner and I have the owner's permission and authority to do so.)

**OFFICE USE ONLY**

Census: _____			
Square Footages: _____			
Type of Construction: _____	Occupancy Classification: _____	Occupant Load: _____	Flood Zone: _____
Pre-Paid Amount: _____	Paid By: _____	Receipt # : _____	
Valuation: _____	Permit Fee: _____	Plan Review: _____	
Sewer Capacity Fee: _____	Water Resource Fee: _____	Eng. Plan Rev: _____	
Zoning: _____	Lot Size: _____	Lot Coverage: _____	
Minimum Setbacks: Front: _____	Side: _____	Street Side: _____	Rear: _____
Easements: _____			
Comments: _____			

	REVIEWED BY <small>(STAFF INITIALS)</small>	DATE <small>(MM/DD/YY)</small>
SUBMITTAL		
P&Z		
BLDG.		
ENG.		
APPROVAL		
TYPED		

**CITY OF BULLHEAD CITY  
OWNER BUILDER - DECLARATION OF INTENT**

**Project Address:** \_\_\_\_\_ **Permit #:** \_\_\_\_\_  
**Permit Type:** \_\_\_\_\_

**Property Owner Name:** \_\_\_\_\_

**Mailing Address:** \_\_\_\_\_

**Phone Number:** \_\_\_\_\_

<b>Initial One</b>	<b>OWNER BUILDER CONTRACTOR LICENSE EXEMPTION DECLARATION</b>
	I understand that the "Handyman" exemption does not apply to any construction project which requires a building permit and/or the total cost of materials and labor are more than \$1000. I understand that all contractors must have a valid Arizona Registrar of Contractors license and a valid City of Bullhead City business license.
	<b><u>Improvements to Vacant or Improved Property (intended for occupancy solely by the owner):</u></b> I am exempt from Arizona contractor license laws on the basis that I am the owner/developer of the property and the property will not be used by members of the public, sold or rented for at least one year after completion of this project (ARS § 32-1121.A.5).
	<b><u>Improvements To Vacant Property (intended for use by members of the public, sale or rent):</u></b> I am exempt from Arizona contractor license laws on the basis that I am the owner/developer of the property and I will contract with a licensed general contractor to provide all construction services (ARS § 32-1121.A.6). <ul style="list-style-type: none"> <li>• General Contractor information to be provided on reverse.</li> </ul>
	<b><u>Improvements To Improved Property (intended for use by members of the public, sale or rent):</u></b> I am exempt from Arizona contractor license laws on the basis that I am the owner/developer of the property and I will contract with licensed general contractors or specialty contractors to provide all construction services. (ARS § 32-1121.A.6). <ul style="list-style-type: none"> <li>• General Contractor and/or Specialty Contractor information to be provided on reverse.</li> </ul>
<b>Initial One</b>	<b>SALES TAX DECLARATION</b>
	<b><u>I am constructing minor improvements to real property.</u></b> I understand that all construction contractors utilized in connection with this project are liable for payment of the City of Bullhead City sales tax.
	<b><u>I am constructing substantial improvements to real property for my own use.</u></b> I do not intend to sell the improved real property within twenty-four (24) months after completion. I understand that all construction contractors utilized in connection with this project are liable for payment of the City of Bullhead City sales tax. I also agree to furnish a list of amounts paid to all contractors to the Finance Department of the City of Bullhead City within fifteen (15) days after final inspection. I further understand that if I sell the project within twenty-four (24) months after completion, I am liable for sales tax on the sales price, less applicable credit for taxes previously paid.
	<b><u>I am constructing substantial improvements to real property which I intend to sell upon completion.</u></b> I declare liability for payment of City of Bullhead City sales tax which I understand is due and payable upon the full sales price at the close of escrow or transfer of title, whichever occurs first. I further understand that if the project is not sold within twenty-four (24) months after completion, I am liable for payment of all sales tax on construction costs previously claimed as exempt (including land). If this box has been checked, you must go to the Arizona Department of Revenue to obtain a Sales Tax Number prior to permit issuance, if you do not already have one.
<b>Initial One</b>	<b>WORKMANS COMPENSATION DECLARATION</b>
	I certify that in the performance of the work for which this permit is issued, I will not employ any person in any manner so as to become subject to the Worker's Compensation Laws of Arizona. I understand that if I become subject to the Worker's Compensation provisions of the labor code, I must comply with its provisions or this permit will be deemed revoked.
	I hereby affirm that I have a certificate of consent to self-insure, or a certificate of Worker's Compensation Insurance, or a certified copy. <input type="checkbox"/> Certified copy is hereby furnished. <input type="checkbox"/> Certified copy is filed with the City.

**Signature of Property Owner:** \_\_\_\_\_ **Date:** \_\_\_\_\_

**CONTRACTOR LIST (For Declaration of Intent)**

**Permit #:** \_\_\_\_\_

**Contractor** \_\_\_\_\_ **Type:** \_\_\_\_\_  
Mailing Address: \_\_\_\_\_  
City: \_\_\_\_\_ State: \_\_\_\_\_ Zip: \_\_\_\_\_  
Office #: \_\_\_\_\_ Cell #: \_\_\_\_\_ Fax #: \_\_\_\_\_  
Email: \_\_\_\_\_  
AZ Registrar of Contractors Number: \_\_\_\_\_  
Arizona Transaction Privilege Tax Number: \_\_\_\_\_  
City of Bullhead City Business License Number: \_\_\_\_\_

---

**Sub-Contractor** \_\_\_\_\_ **Type:** \_\_\_\_\_  
Mailing Address: \_\_\_\_\_  
City: \_\_\_\_\_ State: \_\_\_\_\_ Zip: \_\_\_\_\_  
Office #: \_\_\_\_\_ Cell #: \_\_\_\_\_ Fax #: \_\_\_\_\_  
Email: \_\_\_\_\_  
AZ Registrar of Contractors Number: \_\_\_\_\_  
Arizona Transaction Privilege Tax Number: \_\_\_\_\_  
City of Bullhead City Business License Number: \_\_\_\_\_

---

**Sub-Contractor** \_\_\_\_\_ **Type:** \_\_\_\_\_  
Mailing Address: \_\_\_\_\_  
City: \_\_\_\_\_ State: \_\_\_\_\_ Zip: \_\_\_\_\_  
Office #: \_\_\_\_\_ Cell #: \_\_\_\_\_ Fax #: \_\_\_\_\_  
Email: \_\_\_\_\_  
AZ Registrar of Contractors Number: \_\_\_\_\_  
Arizona Transaction Privilege Tax Number: \_\_\_\_\_  
City of Bullhead City Business License Number: \_\_\_\_\_

---

**Sub-Contractor** \_\_\_\_\_ **Type:** \_\_\_\_\_  
Mailing Address: \_\_\_\_\_  
City: \_\_\_\_\_ State: \_\_\_\_\_ Zip: \_\_\_\_\_  
Office #: \_\_\_\_\_ Cell #: \_\_\_\_\_ Fax #: \_\_\_\_\_  
Email: \_\_\_\_\_  
AZ Registrar of Contractors Number: \_\_\_\_\_  
Arizona Transaction Privilege Tax Number: \_\_\_\_\_  
City of Bullhead City Business License Number: \_\_\_\_\_

---

**Sub-Contractor** \_\_\_\_\_ **Type:** \_\_\_\_\_  
Mailing Address: \_\_\_\_\_  
City: \_\_\_\_\_ State: \_\_\_\_\_ Zip: \_\_\_\_\_  
Office #: \_\_\_\_\_ Cell #: \_\_\_\_\_ Fax #: \_\_\_\_\_  
Email: \_\_\_\_\_  
AZ Registrar of Contractors Number: \_\_\_\_\_  
Arizona Transaction Privilege Tax Number: \_\_\_\_\_  
City of Bullhead City Business License Number: \_\_\_\_\_

---

**Sub-Contractor** \_\_\_\_\_ **Type:** \_\_\_\_\_  
Mailing Address: \_\_\_\_\_  
City: \_\_\_\_\_ State: \_\_\_\_\_ Zip: \_\_\_\_\_  
Office #: \_\_\_\_\_ Cell #: \_\_\_\_\_ Fax #: \_\_\_\_\_  
Email: \_\_\_\_\_  
AZ Registrar of Contractors Number: \_\_\_\_\_  
Arizona Transaction Privilege Tax Number: \_\_\_\_\_  
City of Bullhead City Business License Number: \_\_\_\_\_



# THE CITY OF BULLHEAD CITY DEVELOPMENT SERVICES DEPARTMENT

## SITE PLAN CHECKLIST

ALL PERMITS APPLICATIONS WILL REQUIRE THE FOLLOWING INFORMATION PROVIDED ON TWO 8.5" X 11" SITE PLANS

- \_\_\_\_\_ 1. SHOW THE COMPLETE OUTLINE OR SHAPE OF THE SUBJECT PROPERTY TO BE PERMITTED.
  
- \_\_\_\_\_ 2. SHOW ALL PROPERTY LINE LENGTHS IN RESPECT TO THE OUTLINE OF THE PROPERTY.
  
- \_\_\_\_\_ 3. SHOW THE LOCATION, ELIVATIONS AND TYPE OF PROPERTY PINS (SEE ILLUSTRATION): THE CITY MAY REQUIRE A SURVEYORS CERTIFICATION OF THE PROPERTY.
  
- \_\_\_\_\_ 4. SHOW THE LOCATION AND DIMENSIONS OF ALL EXISTING AND PROPOSED STRUCTURES ON THE SUBJECT PROPERTY, INCLUDING THE SQUARE FOOTAGE COUNTS FOR EACH STRUCTURE/USE ON THE PROPERTY (BOTH HORIZONTAL & VERTICAL).
  
- \_\_\_\_\_ 5. SHOW THE DISTANCES OF ALL STRUCTURES FROM EACH OTHER (BOTH HORIZONTAL & VERTICAL).
  
- \_\_\_\_\_ 6. SHOW THE DISTANCES OF ALL STRUCTURES FROM THE PROPERTY LINES OF THE SUBJECT PROPERTY (BOTH HORIZONTAL & VERTICAL).
  
- \_\_\_\_\_ 7. SHOW THE LOCATION AND DIMENSIONS OF ANY EASEMENT(S) ON THE SUBJECT PROPERTY.
  
- \_\_\_\_\_ 8. SHOW THE ORIGIN AND TERMINATION OF ALL UTILITIES ON THE PROPERTY.
  
- \_\_\_\_\_ 9. SHOW THE NAME(S) OF STREET(S) ADJACENT TO THE PROPERTY.
  
- \_\_\_\_\_ 10. SHOW ALL GRADE ELIVATIONS AT THE PROPERTY PINS, THE FINISH FLOOR ELEVATION(S) FOR ALL STRUCTURES INCLUDING ALL MAJOR (3' +/-) GRADE CHANGES AND/OR SLOPES BY LABLING THE TOP AND TOE OF EACH.

**RESIDENTIAL ACCESSORY STRUCTURES  
FEE CALCULATION WORKSHEET  
ESTIMATE\***

Address: \_\_\_\_\_

Log #: R \_\_\_ - \_\_\_\_\_

	Size (Sq Ft)	Factor Per Sq Ft	Valuation
Room Addition		x \$ 40.73 =	
Garage, Shed or Storage Room		x \$ 40.73 =	
Awning, Carport, Deck Or Similar		x \$ 16.36 =	
Other (see fee schedule)		x \$ _____ =	
Air Conditioning		x \$ 2.68 =	
Fire Sprinklers		x \$ 1.61 =	
<b>TOTAL SQ FT</b>		<b>TOTAL VALUATION</b>	
<b>Building Permit Fee</b> (From Fee Schedule)		Census	Occupancy / Building Type
<b>+ Plan Review Fee</b> (65% of Bldg Permit Fee)		Units	# of Bedrooms
<b>+ Flood Plain Permit Fee</b> (If applicable)	\$120.00	To determine if a lot is in a FEMA designated floodplain contact the City's Engineering division at 928-763-0128.	Owner is also responsible for hiring an AZ licensed registrant to set finished floor elevation and complete FEMA forms.
<b>= TOTAL FEES</b>			

Plan Review fees are due at submittal \$ \_\_\_\_\_

Comments: \_\_\_\_\_

---



---



---

\*Fees quoted are based on the City's adopted Comprehensive Fee Schedule which is available at [www.bullheadcity.com](http://www.bullheadcity.com). All fees quoted are estimates based on information provided. Final fees, including those for any additional permits required (grading, retaining walls, fences, etc.), will be calculated during the plan review process.

**A3.40.021.02 – Valuation Fees**

\$1.00 - \$500.00	\$21.68
\$501.00 - \$2,000.00	\$21.68 1st \$500.00, plus \$2.90 per \$100.00 or fraction of, up to and including \$2,000
\$2,001.00 - \$25,000.00	\$65.18 1st \$2,000.00, plus \$13.02 per \$1,000.00 or fraction of, up to and including \$25,000
\$25,001.00 - \$50,000.00	\$364.64 1st \$25,000.00, plus \$9.39 per \$1,000.00 or fraction of, up to and including \$50,000
\$50,001.00 - \$100,000.00	\$599.39 1st \$50,000.00, plus \$6.48 per \$1,000.00 or fraction of, up to and including \$100,000
\$100,001.00 - \$500,000.00	\$923.39 1st \$100,000.00, plus \$5.04 per \$1,000.00 or fraction of, up to and including \$500,000
\$500,001.00 - \$1,000,000.00	\$2,939.39 1st \$500,000.00, plus \$4.34 per \$1,000.00 or fraction of, up to and including \$1,000,000
\$1,000,000.00 and up.	\$5,109.39 1st \$1,000,000.00, plus \$2.89 Per \$1,000.00 or fraction of.

**A3.40.021.03 - Inspection Fees**

Outside normal business hours	\$50.00 per hour*
Re-inspection	\$50.00 per hour*
Inspection for which no fee is specifically indicated	\$50.00 per hour*
Additional plan review required by changes, etc. to approved plans	\$50.00 per hour*
Laboratory testing	\$20.40 per hour, minimum 3 samples

\*Or the total hourly cost to the jurisdiction, whichever is greatest. This cost shall include supervision, overhead, equipment, hourly wages and fringe benefits of the employees involved.

**A3.40.021.04 – Plan Review Fees**

Commercial / Multi-Family Residential	65% (sixty-five percent) of building permit fee
One and Two Family Residential	65% (sixty-five percent) of building permit fee
Residential Standard plans: Submittal of standard plan	75% (seventy-five percent) of building permit fee
Each additional site-specific submittal for site review and administrative costs	50% (fifty percent) of building permit fee
Secondary changes of standard plan	\$50.00 per hour plan review fee (min. one hour)
Medical Marijuana: Dispensary, Infusion Facility, Cultivation Facility, etc.	90% (ninety percent) of building permit fee
All other submittals	65% (sixty-five percent) of building permit fee